

differential pressure gauges PN 100 with double diaphragm DS 4", 6" (100-150mm)

MD16

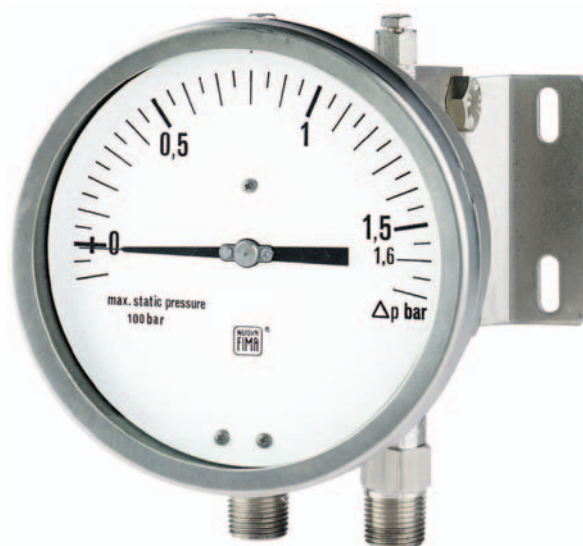

These instruments are used to check filter obstructions, pressure drops, flow rate differences, level, measurements and generally the difference between two pressures of equal or different circuits. The measuring element is formed by two diaphragms, acting on the same movement. In this way the pointer senses only the difference between the two pressures corresponding respectively to upstream and downstream circuit pressure.

2.16.1 - Standard Model

Accuracy: $\pm 2,5\%$ of the full scale value.

Scale amplitude: 180°.

Static pressure: 1500 psi max (100 bar).

Ambient temperature: -13...+149°F (-25...+65 °C).

Process fluid temperature: +302°F (+150 °C).

Protection: IP 55 as per IEC 529.

Process connection: AISI 316L st.st.

Elastic element: AISI 316L/Duratherm st.st.
double diaphragm.

Gasket: VITON and PTFE.

Case: stainless steel.

Ring: stainless steel polished, bayonet lock.

Window: glass.

Movement: stainless steel.

Dial: aluminium, white with black markings.

Pointer: aluminium, micrometric adjustable.

RANGES	mbar	mmH2O	bar	kPa
0...0,4			♦	
0...0,6			♦	
0...1			♦	
0...1,6			♦	
0...2,5			♦	
0...4			♦	
0...6			♦	
0...10			♦	
0...40				♦
0...60				♦
0...100				♦
0...160				♦
0...250				♦
0...400	♦			♦
0...600	♦			♦
0...1000	♦			♦
0...1600	♦	♦		
0...4000		♦		
0...6000		♦		
0...10000				

differential pressure gauges PN 100 with double diaphragm, DS 4", 6" (100-150mm)

MD16

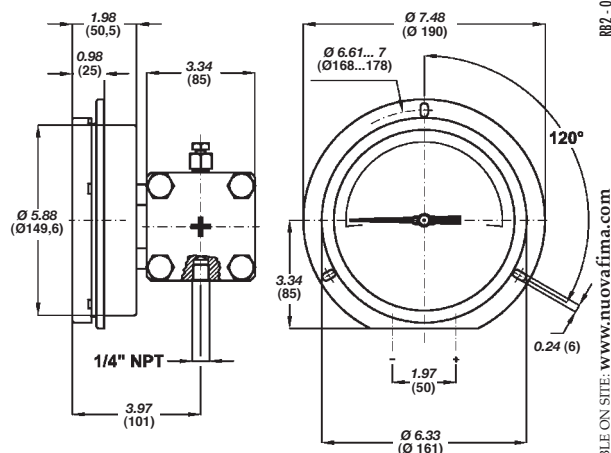
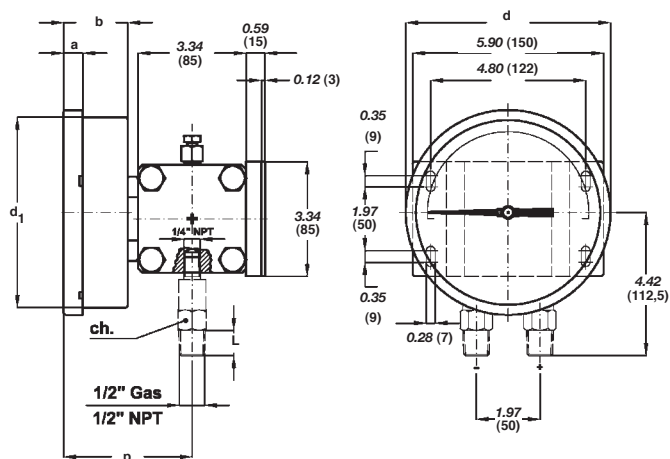

Lower (Mounting code **A**), with back flange
(Option code **C**): DS 4", 6" (100-150mm)

Lower (Mounting code **A**), with front flange (Option
code **F** : DS 4" - 100mm; Option code **E** : DS 6" -
150mm)

dimensions : inches (mm)

Mounting	DS	F	a	b	d	d ₁	p	L	ch	Weight lbs (kg)
Wall	E 4" (100mm)	41M G 1/2 A	0.51 (13)	1.91 (48,5)	4.35 (110,5)	3.98 (101)	3.88 (98,5)	0.79 (20)	0.87 (22)	10.71 (4,86)
Wall	G 6" (150mm)		0.59 (15)	1.99 (50,5)	6.34 (161)	5.89 (149,5)	3.97 (101)	0.79 (20)	0.87 (22)	11.79 (5,35)
Panel	G 6" (150mm)		43M 1/2-14 NPT	1 (25,5)	1.99 (50,5)	6.34 (161)	5.89 (149,5)	3.97 (101)	0.79 (20)	0.87 (22)

OPTIONS

C - Back flange	P02 - Oxygen service (5)
F - Front flange for DN100 instruments	R10 - Glycerine filled case. Ambient temp. +59...+149°F (+15...+65 °C). (8)
E - Front flange for DN150 instruments	R11 - Silicon oil filled case. Ambient temp. -40...+149°F (-40...+65 °C). (6) (8)
C40 - AISI 316 st.st. case and ring (2)	S31 - 2" pipe mounting bracket
E30 - NACE MR0175 version (ISO 15156) (8)	T01 - Tropicalization
E65 - Protection IP65 (3) (8)	T32 - Safety glass window (8)
L22 - Maximum pointer IP65 (4)	2G9 - ATEX versions : II 2G c (8) (9)
M23 - MONEL 400 diaphragms	2D9 - ATEX versions : II 2GD c (8) (9)
Mechanical electric contacts (1)	

- (1) Codes, descriptions and wiring on data-sheet MN14
 (2) Available for ranges ≥ 1 bar. To be ordered with Monel 400 diaphragm.
 (3) To be ordered with Plexiglas window
 (4) Available only for ranges ≥ 1 bar

- (5) Filling of internal chamber with Fluorolube
 (6) Window gasket and blow out vent: VITON
 (8) Not available with electric contacts
 (9) For constructive details see ATEX execution data-sheet

"HOW TO ORDER" SEQUENCE

Section / Model / Case / Mounting / Diameter / Special version / Range / Process connection / Options
2 16 1 A E --- 41M - G 1/2 A M C, E
G 43M - 1/2" NPT M C40...2D9
23F - 1/4" NPT F