

bourdon tube test gauges
all stainless steel construction
class 0,6%
DS 6" (150mm)

MN15



- ✓ - All instruments are supplied with calibration report referred to master primary instrument.

CE Compliance to requirement of PED 97/23/EC

These instruments have been designed for laboratories, instrument testing or recalibration facilities and in other applications where accuracy and repeatability are of primary importance. They can be used with fluids or gasses that do not have high viscosity and do not crystallize. The wetted parts in AISI 316L permits to use them in worse working conditions determined by aggressive ambients or process fluids. Upon request we can supply the calibration certificate issued by an Internationally recognized laboratory of S.I.T. (Servizio Italiano Taratura - Italian Calibration Service).

1.15.1 - Standard Model

- Design:** EN837-1.
- Safety designation:** S1 as per EN 837-2.
- Accuracy class:** 0,6 as per EN 837-1.
- Ambient temperature:** -13...+149 °F (-25...+65 °C).
- Process fluid temperature:** -40...+302°F (-40...+150 °C).
- Calibration temperature:** 68°F (+20 °C).
- Thermal drift:** ±0,4 % / 10 K of range (starting from 68°F - 20°C).
- Working pressure:** max 75% of FSV.
- Overpressure limit:** 30% of FSV.
- Protection degree:** IP 55 as per IEC 529.
- Socket material:** AISI 316L st.st.
- Bourdon tube:** AISI 316L st.st. seamless tube.
- Case:** stainless steel.
- Ring:** stainless steel, bayonet lock.
- Window:** tempered glass.
- Movement:** stainless steel with internal limit stops fro minimum and maximum pressure.
- Dial:** aluminium,white with black markings and anti-parallax mirror band.
- Pointer:** adjustable, aluminium, black, knife-edge micrometer.

| RANGE | Minor graduation | Figure interval | bar | kPa | MPa | psi |
|----------|------------------|-----------------|-----|-----|-----|-----|
| -1...0 | 0,005 | 0,1 | ◆ | | | |
| 0...0,6 | 0,002 | 0,05 | ◆ | | ◆ | |
| 0...1 | 0,005 | 0,1 | ◆ | | ◆ | |
| 0...1,6 | 0,005 | 0,1 | ◆ | | ◆ | |
| 0...2,5 | 0,01 | 0,2 | ◆ | | ◆ | |
| 0...4 | 0,02 | 0,2 | ◆ | | ◆ | |
| 0...6 | 0,02 | 0,5 | ◆ | | ◆ | |
| 0...10 | 0,05 | 1 | ◆ | | ◆ | ◆ |
| 0...16 | 0,05 | 1 | ◆ | | ◆ | ◆ |
| 0...25 | 0,1 | 2 | ◆ | | ◆ | |
| 0...30 | 0,1 | 2 | ◆ | | ◆ | ◆ |
| 0...40 | 0,2 | 2 | ◆ | | ◆ | |
| 0...60 | 0,2 | 5 | ◆ | ◆ | ◆ | ◆ |
| 0...100 | 0,5 | 10 | ◆ | ◆ | | ◆ |
| 0...160 | 0,5 | 10 | ◆ | ◆ | | ◆ |
| 0...250 | 1 | 20 | ◆ | ◆ | | |
| 0...300 | 1 | 30 | ◆ | ◆ | | ◆ |
| 0...400 | 2 | 20 | ◆ | ◆ | | ◆ |
| 0...600 | 2 | 50 | ◆ | ◆ | | ◆ |
| 0...1000 | 5 | 100 | | | | ◆ |
| 0...2000 | 10 | 100 | | | | ◆ |
| 0...3000 | 10 | 200 | | | | ◆ |
| 0...4000 | 20 | 200 | | | | ◆ |
| 0...6000 | 20 | 500 | | | | ◆ |

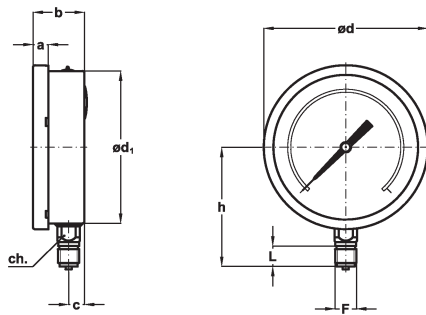

A - LOWER CONNECTION

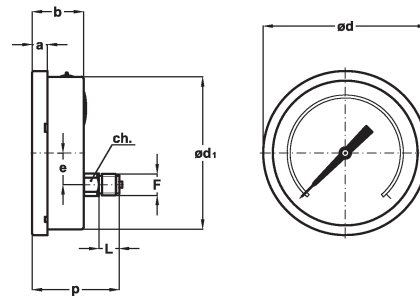

D - BACK CONNECTION

| Mounting | F | a | b | c | ød | ød ₁ | e | h | p | ch | L | Weight |
|----------|-------------------------|-------|--------|--------|-------|-----------------|-------|-------|--------|-------|-------|-----------|
| Lower | 41M - G 1/2 A | 0.59" | 1.91" | 1.98" | 6.33" | 5.88" | | 4.60" | | 0.86" | 0.78" | 2.07 lbs |
| | 43M - 1/2-14 NPT | (15) | (50,5) | (15,5) | (161) | (149,6) | | (117) | | (22) | (20) | (0,94 kg) |
| Back | 41M - G 1/2 A | 0.59" | 1.91" | | 6.33" | 5.88" | 1.22" | | 3.36" | 0.86" | 0.78" | 2.07 lbs |
| | 43M - 1/2-14 NPT | (15) | (50,5) | | (161) | (149,6) | (31) | | (85,5) | (22) | (20) | (0,94 kg) |

dimensions : inches (mm)

PRESSURE GAUGE HOLDER CASE



Instruments with radial connection can be supplied of pressure gauge holder case, code **5VAL**.

OPTIONS

| |
|--|
| B - "U"-clamp, for back connection pressure gauges |
| C - Back flange, for lower connection pressure gauges |
| E - Front flange, for back connection pressure gauges |
| CE1 - S.I.T. certificate for pressure gauges |
| CE3 - S.I.T. certificate for vacuum |
| T32 - Safety glass window |

"HOW TO ORDER" SEQUENCE

| |
|---|
| Section / Model / Case / Mounting / Diameter / Range / Process connection / Options |
| 1 15 1 A G 41M B...E |
| D 43M A40...T32 |